

PROGRAM 1744-S TERM: 08/01/13 TO 07/31/14						
TITLE:	WATERMARKS					
					ALCOM PRINTING	
ITEM NO.	DESCRIPTION	*	BASIS OF	*		*
		*	AWARD	*	Harleysville, PA	*
		*		*	UNIT RATE	COST
I.	ELECTRONIC PREPRESS:	*		*		\$0.00
(a)	Trim/page-size unitper trim/page size unit	*	32	*	\$22.50	\$720.00
(b)	PDF proofs.....per trim/page-size unit	*	32	*	\$2.00	\$64.00
(c)	System timework.....per hour	*	1	*	\$75.00	\$75.00
II.	PRINTING AND BINDING:	*		*		\$0.00
(a)	Printing in four color process.....per trim/page-size unit	*		*		\$0.00
	(1) Makeready and/or Setup	*	32	*	\$119.00	\$3,808.00
	(2) Running.....per 100 copies	*	432	*	\$13.00	\$5,616.00
III.	PAPER:	*		*		\$0.00
(a)	No. 1 Coated Text, Gloss Finish (80 lb.).....per 1000 leaves	*	162	*	\$9.91	\$1,605.42
(b)	No. 1 Coated Cover, Gloss Finish (80 lb.).....per 1000 leaves	*	54	*	\$18.75	\$1,012.50
IV.	PACKING:	*		*		\$0.00
(a)	Bulk Shipments (packing and sealing containers).....per container	*	136	*	\$2.75	\$374.00
	CONTRACTOR TOTALS	*		*		\$13,274.92
	DISCOUNT	*		*	2.00%	\$265.50
	DISCOUNTED TOTALS	*		*		\$13,009.42

COLONIAL PRESS INTL.			GRC ENTERPRISES, INC.			HENLE PRINTING CO.		
		*			*			*
Miami, FL		*	Warrenton, VA		*	Marshall, MN		*
UNIT RATE	COST	*	UNIT RATE	COST	*	UNIT RATE	COST	*
	\$0.00	*		\$0.00	*		\$0.00	*
\$2.00	\$64.00	*	\$20.00	\$640.00	*	\$6.50	\$208.00	*
\$1.00	\$32.00	*	\$3.15	\$100.80	*	\$2.00	\$64.00	*
\$60.00	\$60.00	*	\$85.00	\$85.00	*	\$75.00	\$75.00	*
	\$0.00	*		\$0.00	*		\$0.00	*
	\$0.00	*		\$0.00	*		\$0.00	*
\$50.88	\$1,628.16	*	\$80.00	\$2,560.00	*	\$50.00	\$1,600.00	*
\$10.69	\$4,618.08	*	\$8.60	\$3,715.20	*	\$7.10	\$3,067.20	*
	\$0.00	*		\$0.00	*		\$0.00	*
\$14.21	\$2,302.02	*	\$14.25	\$2,308.50	*	\$12.53	\$2,029.86	*
\$27.62	\$1,491.48	*	\$53.00	\$2,862.00	*	\$32.88	\$1,775.52	*
	\$0.00	*		\$0.00	*		\$0.00	*
\$1.00	\$136.00	*	\$3.50	\$476.00	*	\$2.00	\$272.00	*
	\$10,331.74	*		\$12,747.50	*		\$9,091.58	*
3.00%	\$309.95	*	2.00%	\$254.95	*	5.00%	\$454.58	*
	\$10,021.79	*		\$12,492.55	*		\$8,637.00	*

IPC PRINTING		K-B OFFSET PRINTING, INC.		WBC, INC.	
Baton Rouge, LA		State College, PA		Albuquerque, NM	
UNIT RATE	COST	UNIT RATE	COST	UNIT RATE	COST
	\$0.00		\$0.00		\$0.00
\$6.32	\$202.24	\$12.00	\$384.00	\$0.00	\$0.00
\$1.58	\$50.56	\$5.00	\$160.00	\$5.00	\$160.00
\$73.68	\$73.68	\$75.00	\$75.00	\$80.00	\$80.00
	\$0.00		\$0.00		\$0.00
	\$0.00		\$0.00		\$0.00
\$57.89	\$1,852.48	\$60.00	\$1,920.00	\$60.00	\$1,920.00
\$7.37	\$3,183.84	\$8.50	\$3,672.00	\$50.00	\$21,600.00
	\$0.00		\$0.00		\$0.00
\$14.21	\$2,302.02	\$18.00	\$2,916.00	\$26.50	\$4,293.00
\$35.79	\$1,932.66	\$30.00	\$1,620.00	\$68.00	\$3,672.00
	\$0.00		\$0.00		\$0.00
\$1.68	\$228.48	\$5.00	\$680.00	\$1.50	\$204.00
	\$9,825.96		\$11,427.00		\$31,929.00
5.00%	\$491.30	0.00%	\$0.00	1.00%	\$319.29
	\$9,334.66		\$11,427.00		\$31,609.71

THE PRINT HOUSE		PRODUCTION PRESS		PUBLISHERS PRINTING	
Brooklyn, NY		Jacksonville, IL		Lebanon Junction, KY	
UNIT RATE	COST	UNIT RATE	COST	UNIT RATE	COST
	\$0.00		\$0.00		\$0.00
\$1.00	\$32.00	\$4.50	\$144.00	\$12.72	\$407.04
\$1.00	\$32.00	\$2.50	\$80.00	\$1.05	\$33.60
\$75.00	\$75.00	\$118.00	\$118.00	\$45.00	\$45.00
	\$0.00		\$0.00		\$0.00
	\$0.00		\$0.00		\$0.00
\$37.50	\$1,200.00	\$51.80	\$1,657.60	\$108.84	\$3,482.88
\$9.56	\$4,129.92	\$10.64	\$4,596.48	\$5.31	\$2,293.92
	\$0.00		\$0.00		\$0.00
\$16.43	\$2,661.66	\$13.29	\$2,152.98	\$8.17	\$1,323.54
\$31.33	\$1,691.82	\$25.92	\$1,399.68	\$26.26	\$1,418.04
	\$0.00		\$0.00		\$0.00
\$1.50	\$204.00	\$4.05	\$550.80	\$1.32	\$179.52
	\$10,026.40		\$10,699.54		\$9,183.54
0.25%	\$25.07	3.00%	\$320.99	0.00%	\$0.00
	\$10,001.33		\$10,378.55		\$9,183.54

SEAWAY PRINTING CO., INC.		SVEC CONWAY		TODD ALLAN PRINTING CO.	
Green Bay, WI		Silver Spring, MD		Beltsville, MD	
UNIT RATE	COST	UNIT RATE	COST	UNIT RATE	COST
	\$0.00		\$0.00		\$0.00
\$6.13	\$196.16	\$15.00	\$480.00	\$2.00	\$64.00
\$1.53	\$48.96	\$2.00	\$64.00	\$1.50	\$48.00
\$76.58	\$76.58	\$65.00	\$65.00	\$125.00	\$125.00
	\$0.00		\$0.00		\$0.00
	\$0.00		\$0.00		\$0.00
\$51.05	\$1,633.60	\$85.00	\$2,720.00	\$56.00	\$1,792.00
\$7.15	\$3,088.80	\$9.50	\$4,104.00	\$12.25	\$5,292.00
	\$0.00		\$0.00		\$0.00
\$12.61	\$2,042.82	\$15.00	\$2,430.00	\$14.25	\$2,308.50
\$31.15	\$1,682.10	\$31.00	\$1,674.00	\$32.00	\$1,728.00
	\$0.00		\$0.00		\$0.00
\$1.02	\$138.72	\$1.25	\$170.00	\$1.50	\$204.00
	\$8,907.74		\$11,707.00		\$11,561.50
5.00%	\$445.39	1.00%	\$117.07	5.00%	\$578.08
	\$8,462.35		\$11,589.93		\$10,983.42
AWARDED					

UNIVERSAL PRINTING CO.					
SERVICE		*			*
St. Louis, MO		*	PREVIOUS CONTRACTOR		*
UNIT RATE	COST	*	UNIT RATE	COST	*
	\$0.00	*		\$0.00	*
\$19.19	\$614.08	*	\$15.00	\$480.00	*
\$4.04	\$129.28	*	\$2.00	\$64.00	*
\$96.97	\$96.97	*	\$70.00	\$70.00	*
	\$0.00	*		\$0.00	*
	\$0.00	*		\$0.00	*
\$180.20	\$5,766.40	*	\$63.50	\$2,032.00	*
\$14.56	\$6,289.92	*	\$6.80	\$2,937.60	*
	\$0.00	*		\$0.00	*
\$0.00	\$0.00	*	\$11.20	\$1,814.40	*
\$0.00	\$0.00	*	\$40.00	\$2,160.00	*
\$0.00	\$0.00	*		\$0.00	*
	\$0.00	*	\$2.50	\$340.00	*
	\$12,896.65	*		\$9,898.00	*
1.00%	\$128.97	*	2.00%	\$197.96	*
	\$12,767.68	*		\$9,700.04	*

U. S. GOVERNMENT PRINTING OFFICE
Dallas, TX

GENERAL TERMS, CONDITIONS, AND SPECIFICATIONS

For the Procurement of

Watermarks

as requisitioned from the U. S. Government Printing Office (GPO) by the

U.S. Department of Agriculture

Single Award

CONTRACT TERM: The term of this contract is for the period beginning August 1, 2013 and ending July 31, 2014, plus up to four (4) optional 12-month extension periods that may be added in accordance with the "OPTION TO EXTEND THE TERM OF THE CONTRACT" clause in SECTION 1 of this contract.

BID OPENING: Bids shall be publicly opened at 2:00 p.m., prevailing Dallas, TX time, on July 17, 2013.

BIDDERS, PLEASE NOTE: These specifications have been revised; therefore all bidders are cautioned to familiarize themselves with these specifications before bidding.

BID SUBMISSION: Submit bid in preaddressed envelope furnished with solicitation, or send to: U.S. Government Printing Office, Dallas Regional Procurement Office, 1100 Commerce Street, Room 731, Dallas, TX 75242. Facsimile bids in response to this solicitation are permitted. **Facsimile bids may be submitted directly to GPO, FAX Number (214)767-4101, one bid per facsimile.** The Program number and bid opening date and time must be specified with the bid. Refer to Facsimile Bids in Solicitation Provisions of GPO Contract Terms, GPO Publication 310.2 as revised June 2001.

Abstracts of contract prices are available at: <http://www.gpo.gov/gpo/abstracts/abstract.action?region=Dallas>

Questions concerning this contract should be directed to Julia Russ, telephone (214) 767-0451, ext. 7 (No collect calls) or email jruss@gpo.gov.

SECTION 1. – GENERAL TERMS AND CONDITIONS

GPO CONTRACT TERMS: Any contract which results from this Invitation for Bid will be subject to GPO Contract Terms (GPO Publication 310.2, effective December 1, 1987 (Rev. 6-01)) and Quality Assurance Through Attributes Program for Printing and Binding (Q.A.T.A.P.) (GPO Publication 310.1, effective May 1979, (Rev. 8-02)).

GPO Contract Terms (GPO Publication 310.2) - <http://www.gpo.gov/pdfs/vendors/sfas/terms.pdf>

Q.A.T.A.P. (GPO Publication 310.1) - <http://www.gpo.gov/pdfs/vendors/sfas/qatap.pdf>

DISPUTES: GPO Publication 310.2, GPO Contract Terms, Contract Clause 5. Disputes, is hereby replaced with the June 2008 clause found at <http://www.gpo.gov/pdfs/vendors/contractdisputes.pdf>. This June 2008 clause also cancels and supersedes any other disputes language currently included in existing contractual actions.

QUALITY ASSURANCE LEVELS AND STANDARDS: The following levels and standards shall apply to these specifications:

Product Quality Levels:

- (a) Printing (page related) Attributes -- Level III.
- (b) Finishing (item related) Attributes -- Level III.

Inspection Levels (from ANSI/ASQC Z1.4):

- (a) Non-destructive Tests - General Inspection Level I.
- (b) Destructive Tests - Special Inspection Level S-2.

Specified Standards: The specified standards for the attributes requiring them shall be:

<u>Attribute</u>	<u>Specified Standard</u>
P-7. Type Quality and Uniformity	Average Type Dimension in Publication
P-8. Halftone Match (Single and Double Impression)	Electronic Media
P-10. Process Color Match	Electronic Media

OPTION TO EXTEND THE TERM OF THE CONTRACT: The Government has the option to extend the term of this contract for a period of 12 months by written notice to the contractor not later than 30 days before the contract expires. If the Government exercises this option, the extended contract shall be considered to include this clause, except, the total duration of the contract may not exceed (5) years as a result of, and including, any extension(s) added under this clause. Further extension may be negotiated under the "Extension of Contract Term" clause. See also "Economic Price Adjustment" for authorized pricing adjustment(s).

EXTENSION OF CONTRACT TERM: At the request of the Government, the term of any contract resulting from this solicitation may be extended for such period of time as may be mutually agreeable to the GPO and the contractor.

ECONOMIC PRICE ADJUSTMENT: The pricing under this contract shall be adjusted in accordance with this clause, provided that in no event will any pricing adjustment be made that would exceed the maximum permissible under any law in effect at the time of the adjustment. There will be no adjustment for orders placed during the first period specified below. Pricing will thereafter be eligible for adjustment during the second and any succeeding performance period(s). For each performance period after the first, a percentage figure will be calculated as described below and that figure will be the economic price adjustment for that entire next period. Pricing adjustments under this clause are not applicable to reimbursable postage or transportation costs, or to paper, if paper prices are subject to adjustment by separate clause elsewhere in this contract.

For the purpose of this clause, performance under this contract will be divided into successive periods. The first period will extend from August 1, 2013 to July 31, 2014, and the second and any succeeding period(s) will extend for 12 months from the end of the last preceding period, except that the length of the final period may vary. The first day of the second and any succeeding period(s) will be the effective date of the economic price adjustment for that period.

Pricing adjustments in accordance with this clause will be based on changes in the seasonally adjusted "Consumer Price Index For All Urban Consumers - Commodities less Food" (Index) published monthly in the CPI Detailed Report by the U.S. Department of Labor, Bureau of Labor Statistics.

The economic price adjustment will be the percentage difference between Index averages as specified in this paragraph. An index called the variable index will be calculated by averaging the monthly Indexes from the 12-month interval ending three (3) months prior to the beginning of the period being considered for adjustment. This average is then compared to the average of the monthly Indexes for the 12-month interval ending April 30, 2013, called the base index. The percentage change (plus or minus) of the variable index from the base index will be the economic price adjustment for the period being considered for adjustment.

The Government will notify the contractor by contract modification specifying the percentage increase or decrease to be applied to invoices for orders placed during the period indicated. The contractor shall apply the percentage increase or decrease against the total price of the invoice less reimbursable postage or transportation costs and separately adjusted paper prices. Payment discounts shall be applied after the invoice price is adjusted.

PREAWARD SURVEY: In order to determine the responsibility of the prime contractor or any subcontractor, the Government reserves the right to conduct an on-site preaward survey at the contractor's/subcontractor's facility or to require other evidence of technical, production, managerial, financial, and similar abilities to perform, prior to the award of a contract.

ASSIGNMENT OF JACKETS, PURCHASE AND PRINT ORDERS: A GPO jacket number will be assigned and a purchase order issued to the contractor to cover work performed. The purchase order will be supplemented by an individual print order for each job placed with the contractor. The print order, when issued, will indicate the quantity to be produced and any other information pertinent to the particular order.

ORDERING: Items to be furnished under the contract shall be ordered by the issuance of print orders by the Government. Orders may be issued under the contract from August 1, 2013 through July 31, 2014 plus for such additional periods as the contract is extended. All print orders issued hereunder are subject to the terms and conditions of the contract. The contract shall control in the event of conflict with any print order. A print order shall be "issued" for purposes of the contract, when it is either deposited in the U.S. Postal Service mail or otherwise furnished to the contractor in conformance with the schedule.

REQUIREMENTS: This is a requirements contract for the items and for the period specified herein. Shipment/delivery of items or performance of work shall be made only as authorized by orders issued in accordance with the clause entitled "Ordering". The quantities of items specified herein are estimates only, and are not purchased hereby. Except as may be otherwise provided in this contract, if the Government's requirements for the items set forth herein do not result in orders in the amounts or quantities described as "estimated", it shall not constitute the basis for an equitable price adjustment under this contract.

Except as otherwise provided in this contract, the Government shall order from the contractor all the items set forth which are required to be purchased by the Government activity identified on page 1.

The Government shall not be required to purchase from the contractor, requirements in excess of the limit on total orders under this contract, if any.

Orders issued during the effective period of this contract and not completed within that time shall be completed by the contractor within the time specified in the order, and the rights and obligations of the contractor and the Government respecting those orders shall be governed by the terms of this contract to the same extent as if completed during the effective period of this contract.

If shipment/delivery of any quantity of an item covered by the contract is required by reason of urgency prior to the earliest date that shipment/delivery may be specified under this contract, and if the contractor will not accept an order providing for the accelerated shipment/delivery, the Government may procure this requirement from another source.

The Government may issue orders which provide for shipment/delivery to or performance at multiple destinations.

Subject to any limitations elsewhere in this contract, the contractor shall furnish to the Government all items set forth herein which are called for by print orders issued in accordance with the "Ordering" clause of this contract.

PAYMENT: Submit all vouchers to: Comptroller, Stop FMCE, Office of Financial Management, U.S. Government Printing Office, Washington, DC 20401.

SECTION 2. - SPECIFICATIONS

SCOPE: These specifications cover the production of a separate cover, saddle-stitched, newsletter requiring such operations as electronic pre-press, proofs, four color process printing, binding, packing, and distribution.

TITLE: Watermarks

FREQUENCY OF ORDERS: Approximately 2 orders per year

QUANTITY: Approximately 12,000 to 20,000 copies per order with an average of 13,500 copies per order.

NUMBER OF PAGES: Approximately 12 pages plus cover per order.

TRIM SIZE: 8-1/2" x 11"

GOVERNMENT TO FURNISH: Print orders and electronic media with all page elements (text and illustrations) in proper position.

Platform: Windows

Storage Media: CD or File Transfer Protocol (FTP)

Software: Adobe InDesign. Files will be furnished in native application format.

Note: All software upgrades (for specified applications) that may occur during the term of the contract must be supported by the contractor.

Fonts: All printer and screen fonts will be furnished. The contractor is cautioned that furnished fonts are the property of the Government and/or its originator. All furnished fonts are to be eliminated from the contractor's archive immediately after completion of the contract.

An electronic copy of GPO Form 2678 (Blue Label) and 917 Selection Certificate for shipping Departmental Random Copies. (GPO Form 2678 should be printed on blue paper.)

An electronic copy of GPO Form 905 Labeling and Marking Specifications.

An electronic copy GPO Form 2682 Specifications for Packing, Labeling, and Palletizing.

Contractor must print and reproduce forms as necessary.

NOTE: In lieu of sending physical media to the contractor, the Department may send electronic files using File Transfer Protocol (FTP). After award, the contractor must provide the Department with the contractor's FTP site address, a user name and a password, if required. The Department will send the contractor the GPO Form 2511 via facsimile or email the same day that the electronic files are sent to the contractor via FTP.

Identification markings such as register marks, commercial identification marks of any kind, etc., except GPO imprint, form number, and revision date, carried in the electronic files, must not print on finished product.

CONTRACTOR TO FURNISH: All materials and operations, other than those listed under "Government to Furnish", necessary to produce the products in accordance with these specifications.

Contractor must have the capability to transmit and receive files via FTP and/or email transmission.

ELECTRONIC PREPRESS: Prior to image processing, the contractor shall perform a basic check (preflight) of the furnished media and publishing files to assure correct output of the required reproduction image. Any errors, media damage, or data corruption that might interfere with proper file image processing must be reported to the contract administrator.

The contractor shall create or change any necessary trapping, set proper screen angles and screen frequency, and define file output selection for the imaging device being utilized. Furnished files must be imaged as necessary to meet the assigned quality level.

Prior to making any revisions, the contractor shall copy the furnished files and make all changes from the copy unless otherwise indicated.

PROOFS: Contractor to submit one "Press Quality" PDF "soft" proof (for content only) of the entire publication, using the same Raster Image Processor (RIP) that will be used to produce the final printed product. PDF proof will be evaluated for text flow, image position, and color breaks. Proof will not be used for color match.

If any contractor's errors are serious enough in the opinion of the GPO to require revised proofs, the revised proofs are to be provided at no expense to the Government. No extra time can be allowed for this reproofing; such operations must be accomplished within the original production schedule allotted in the specifications.

The contractor must not print prior to receipt of an "OK to Print."

STOCK/PAPER: The specifications of all paper furnished must be in accordance with those listed herein or listed for the corresponding JCP Code numbers in the "Government Paper Specification Standards No. 12" dated March 2011.

White No. 1 Coated Text, Gloss-Finish basis weight: 80 lbs per 500 sheets, 25 x 38", equal to JCP Code A181.

Note: Exception to Paper Specification Standards (March 2011 No. 12), under "Testing"- The acceptance criteria in Part 4 SHALL apply for Opacity ONLY.

White No. 1 Coated Cover, Gloss-Finish, basis weight: 80 lbs per 500 sheets, 20 x 26", equal to JCP Code L11.

Color of paper furnished shall be of a uniform shade and a close match by visual inspection of the JCP and/or attached color sample(s). The Contracting Officer reserves the right to reject shipments of any order printed on paper the color of which, in his opinion, materially differs from that of the color sample(s).

PRINTING: Print head-to-head in four-color process throughout.

MARGINS: Adequate gripper margins throughout.

BINDING: Saddle-wire stitch in two places and trim three sides. Each product must contain complete 4-page signature after trimming. Single leaves connected with a lip (i.e., binding stub) to left or right side of stitches will not be allowed.

PACKING: Shrink-film wrap in units of 40. Pack in shipping containers not to exceed 40 pounds when fully packed. Shipping containers shall have a minimum bursting strength of (275 pounds per square inch) or a minimum edge crush test (ECT) of (44 pounds per inch width).

LABELING AND MARKING: Reproduce shipping container label from furnished repro, fill in appropriate blanks and attach to shipping containers. Contractor must reproduce furnished forms and labels as needed.

SAMPLES: When indicated on the print order or otherwise requested, two samples shall be sent to: U.S. Government Printing Office, Regional Procurement Office, 1100 Commerce Street, Room 731, Dallas, Texas 75242, Attn: Samples.

These samples cannot be deducted from the total quantity ordered. The package or envelope containing the samples shall be identified by the GPO jacket number, program number, print order number, title, and include a facsimile of the print order on which they were ordered. These samples should be shipped in compliance with the specified schedule on the individual print order.

DEPARTMENTAL RANDOM COPIES (BLUE LABEL): All orders must be divided into equal sublots in accordance with the chart below. A random copy must be selected from each subplot. Do not choose copies from the same general area in each subplot. The contractor will be required to execute a statement furnished by GPO certifying that copies were selected as directed. The random copies constitute a part of the total quantity ordered, and no additional charge will be allowed.

Books		Forms	
Quantity Ordered	Number of Sublots	Quantity Ordered	Number of Sublots
500 - 3,200	50	12,000 - 35,000	125
3,201 - 10,000	80	35,001 and over	200
10,001 - 35,000	125		
35,001 and over	200		

These randomly selected copies must be packed separately and identified by a special government-furnished blue label, affixed to each affected container. The container and its contents shall be recorded separately on all shipping documents and sent in accordance with the distribution list to U.S. Geological Survey, Attn: Scott Wilson/Dave Marks, 700 Cajundome Blvd., Lafayette, LA 70506.

A copy of the print order/specification and a signed Government-furnished certificate of selection, must be included.

A copy of the Government-furnished certificate must accompany the invoice sent to U.S. Government Printing Office, Financial Management Service, for payment. Failure to furnish the certificate may result in delay in processing the invoice.

QUALITY ASSURANCE RANDOM COPIES: In addition to the Departmental Random Copies (Blue Label), the contractor may be required to submit quality assurance random copies to test for compliance against specifications. The print order will indicate the number required, if any. When ordered, the contractor must divide the entire order into equal sublots and select a copy from a different general area of each subplot. The contractor will be required to execute a statement furnished by GPO certifying that copies were selected as directed. Copies will be paid for at the running rate offered in the contractor's bid and their cost will not be a consideration for award. A copy of the purchase order/specifications must be included.

Business Reply Mail labels will be furnished for mailing the quality assurance random copies. The copies are to be mailed at the same time as the first scheduled shipment. A U.S. Postal Service approved Certificate of Mailing, identified by Program, Print Order, Jacket, and Purchase Order numbers, must be furnished with billing as evidence of mailing.

DISTRIBUTION: Deliver f.o.b. destination as follows:

U.S. Army Corps of Engineers, Attn: Scott Riecke/Rachel Rodi, 7400 Leake Avenue, New Orleans, LA 70118 – 8,500 pamphlets

U.S. Geological Survey, Attn: Scott Wilson, 700 Cajundome Blvd., Lafayette, LA 70506 – 3,000 pamphlets

Coastal Protection and Restoration Authority, Attn: Jacquelyn A. H. Johnson, 450 Laurel Street, Suite 1501 Chase Tower North, Baton Rouge, LA 70801 – 1,000 pamphlets.

Natural Resources Conservation Service, Attn: Brett Mann/Adele Swearingen, 3737 Government Street, Alexandria, LA 71302 – 1,000 pamphlets

For each order placed, contractor must notify the ordering agency on the same day that the product ships/delivers via e-mail sent to Holly.Martien@la.usda.gov and jruss@gpo.gov (or to the address furnished on the Print Order). The subject line of this message shall be “Distribution Notice for Program 1744-S, Print Order XXXXX”. The notice must provide all applicable tracking numbers, shipping method, and Title. Contractor must be able to provide copies of all delivery, mailing, and shipping receipts upon agency request.

When files are furnished on CD, material must be picked up from Koupal Communications and delivered to the Department at contractor's expense. Material will be available for pickup 1 hour after notification.

SCHEDULE: Adherence to this schedule must be maintained. Contractor must not start production of any job prior to receipt of the individual print order (GPO Form 2511).

The following schedule begins the workday after notification of the availability of print order and furnished material; the workday after notification will be the first workday of the schedule. When files are furnished on CD, material will be available for pickup 1 hour after notification.

- Contractor must make complete distribution and delivery within 15 workdays.
- Email proofs within five (5) workdays of the receipt of the print order and government furnished materials. The PDF proof must be emailed to: Billk@koupal-communications.com, Holly.Martien@la.usda.gov and aaron.ramsey@la.usda.gov . Contractor must call Holly Martien at ((318) 473-7762) to confirm receipt.
- The department will approve the proof or approve the proof with comments, within one (1) workday of receipt of the proof. Proof approval will be delivered to the contractor by Bill Koupal, Holly Martien, or Aaron Ramsey via email.

The ship/deliver date indicated on the print order is the date products ordered for delivery f.o.b. destination must be delivered to the destination(s) specified.

Contractors are to report information regarding each order for compliance reporting purposes and include date of delivery (or shipment if applicable) for proofs and delivery schedules in accordance with the contract requirements by contacting the Government Printing Office, Dallas, TX via e-mail to efaxdallas@gpo.gov or faxing 1(800) 865-5193 or by calling (214) 767-0451. Personnel receiving the e-mail or call will be unable to respond to questions of a technical nature or transfer any inquiries.

SECTION 3. - DETERMINATION OF AWARD

The Government will determine the lowest bid by applying the prices offered in the "Schedule of Prices" to the following units of production which are the estimated requirements to produce orders for 12 months under this contract. These units do not constitute, nor are they to be construed as, a guarantee of the volume of work which may be ordered during a like period of time.

The following item designations correspond to those listed in the "Schedule of Prices".

- | | | | |
|------|-----|-----|-----|
| I. | (a) | 32 | |
| | (b) | 32 | |
| | (c) | 1 | |
| II. | | (1) | (2) |
| | (a) | 32 | 432 |
| III. | (a) | 162 | |
| | (b) | 54 | |
| IV. | (a) | 136 | |

SECTION 4. - SCHEDULE OF PRICES

Bids offered are f.o.b. destination for all other shipments.

Prices must include the cost of all required materials and operations for each item listed in accordance with these specifications.

Bidder must make an entry in each of the spaces provided. Bids submitted with any obliteration, revision, or alteration of the order and manner of submitting bids may be declared nonresponsive.

An entry of NC (No Charge) shall be entered if bidder intends to furnish individual items at no charge to the Government.

Bids submitted with NB (No Bid) or blank spaces for an item may be declared nonresponsive.

The Contracting Officer reserves the right to reject any offer that contains prices for individual items of production (whether or not such items are included in the Determination of Award) that are inconsistent or unrealistic in regard to other prices in the same offer or to GPO prices for the same operation if such action would be in the best interest of the Government.

All vouchers submitted to the GPO shall be based on the most economical method of production. Fractional parts of 1,000 will prorated at the per 1,000 rate.

Cost of all required paper must be charged under Item III.

I. ELECTRONIC PREPRESS: The prices offered must be all-inclusive for output from electronic media and shall include the cost of all materials and operations as applicable including output of original or revised pages from electronic media.

- (a) Trim/page-size unitper trim/page-size unit.....\$ _____
- (b) PDF proofs.....per trim/page-size unit.....\$ _____
- (c) System timework.....per hour.....\$ _____

Electronic pre-press operations which cannot be properly classified under any other item shall be charged as "System Timework". Any charge made under "System Timework" must be supported by a statement outlining in detail the operation for which payment is claimed. In case of dispute, the Contracting Officer reserves the right to be the final judge as to the operations and/or number of hours chargeable under item (c).

(Initials)

II. PRINTING AND BINDING:

<u>Makeready and/or Setup</u>	<u>Running Per</u>
(1)	<u>1,000 Copies</u>
	(2)

(a) Printing in four-color process.....per trim/page-size unit.....\$ _____ \$ _____

III. PAPER:

Payment for all paper supplied by the contractor under the terms of these specifications, as ordered on the individual print orders, will be based on the net number of leaves furnished for the product(s) ordered. The cost of any paper required for makeready or running spoilage must be included in the prices offered.

Computation of the net number of leaves will be based on each page-size leaf.

Per 1,000 leaves

(a) No. 1 Coated Text, Gloss Finish (80 lb).....\$ _____

(b) No. 1 Coated Cover, Gloss Finish (80 lb).....\$ _____

IV. PACKING:

(a) Bulk shipments (packing and sealing containers).....per container.....\$ _____

INSTRUCTIONS FOR BID SUBMISSION: Fill out "SECTION 4. - "SCHEDULE OF PRICES" ", initialing or signing each page in the space provided. Submit two copies (original and exact duplicate) of the "SCHEDULE OF PRICES" with two copies of the GPO Form 910 "BID" form. Do not enter bid prices on GPO Form 910; prices entered in the "SCHEDULE OF PRICES" will prevail.

Bidder _____

(City and State)

By _____
(Signature and title of person authorized to sign this bid)

(Person to be contacted)

(Telephone Number)

(Initials)

IMPORTANT

GPO Form 2682 (9-87) P. 51688-1

UNITED STATES GOVERNMENT PRINTING OFFICE

Specifications for Packing, Labeling, and Palletizing

Packing, Labeling, and Palletizing must be in accordance with the requirements as stated in GPO Contract Terms (Pub. 310.2). Nonconformance with the requirements may be cause for rejection.

Reproduced below are significant extracts from the packing, labeling, and palletizing articles contained in GPO Contract Terms (Pub. 310.2). Questions regarding these articles should be directed to the contracting officer.

Packing.

Each packing unit must be uniform in size and quantity contained therein. Unless otherwise indicated, each shipping container must not exceed 45 pounds when fully packed. Quantities which fill less than one-half a shipping container may be wrapped in shipping bundles.

Shipping containers. Only new corrugated or solid fiberboard containers may be used. Containers must be made in accordance with Federal Specification PPP-B-636 and any amendments thereto. Unless otherwise provided in the specifications, bursting strength shall be 275 pounds per square inch minimum. Containers must be packed solidly (top and sides) with the material laid flat on the bottom of the containers (never stand on end); top and bottom pads of corrugated fiberboard shall be used and be in solid contact with the top and bottom of the container. In the event the material does not fit snugly on the top or sides, open-

cell pads or thicknesses of corrugated board must be added.

Labeling and Marking.

The label must be reproduced (same size) from the facsimile in black ink on white paper. The label must be filled in accurately and legibly, using bold characters at least $\frac{1}{4}$ " high, except the "From" box which may be smaller.

Palletizing.

When indicated in specifications, the contractor will be required to furnish pallets for bulk shipments, in shipping containers, when the containers fill two layers or more on the pallet.

Pallets must be Type III, Size 2, Group 2 (or Group 3 at contractor's option) made in accordance with Federal Specification NN-P-71C and any amendments thereto. Full entry must be on the long dimension. Maximum height allowed including pallet is 55". Pack flush to corners.

Note.—Noncompliance with the packaging, labeling, and/or palletizing specifications may be cause for the Government to reject the shipment, at destination, and return it to the contractor at his expense. After giving notice of the deficiency and affording the contractor an opportunity to correct, the Government may, at its option, repackage, relabel, and/or repalletize in accordance with the specifications and charge all costs to the contractor.

Stringer and Deckboard Design for Type III, Four-way (Partial) Flush Pallet

6.2 Ordering Data:

- a) Federal Specification Pallets, Material Handling, Wood, Stringer Construction, 2-way and 4-way (partial), NN-P-71C, dated 9-10-73.
- b) Classification:
 - 1. Type III—four-way (partial), flush, assembled, nonreversible.
 - 2. Size 2—40" x 48"
 - 3. Wood Group II—medium density woods (softwoods), or Wood Group III—high density woods (hardwoods).
 - 4. Grade A—untreated.
- c) Preproduction model not required.
- d) Moisture content as per specification.
- e) Manufacturer's identification not required.
- f) Bundling for shipment not required.

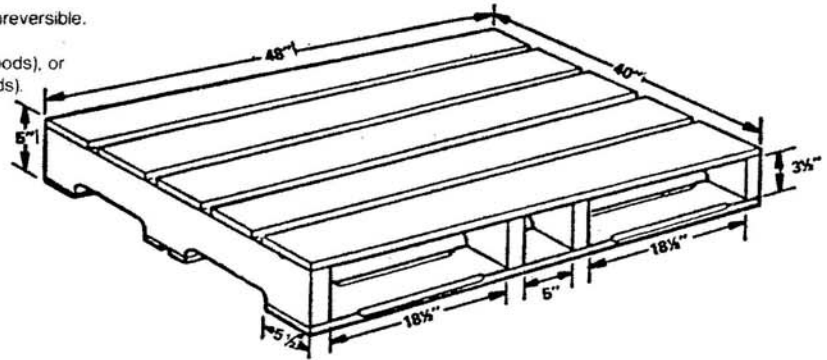

NN-P-71C

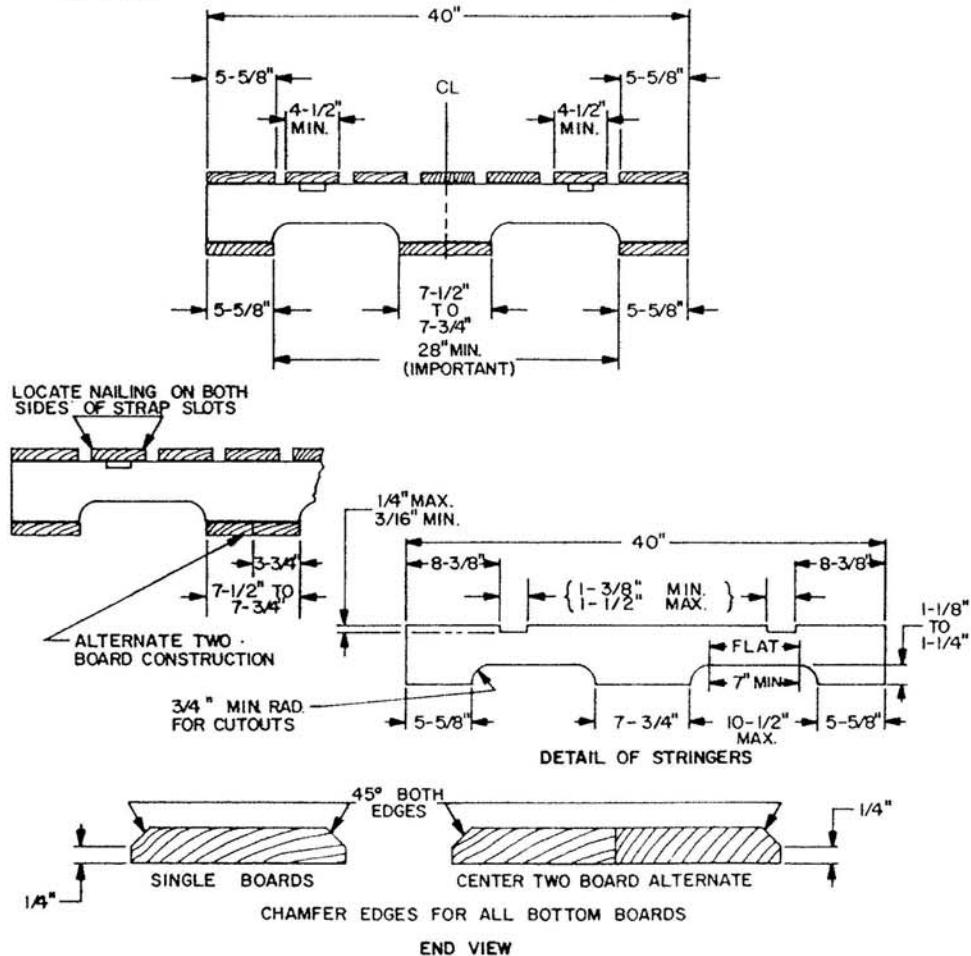

- 1. Dimensions are in inches.
- 2. Notches are to be centered about the centerline (CL).
- 3. Corners of notches shall be rounded as indicated.
- 4. One or two bottom deckboards may be used at the center.

U.S. GOVERNMENT PRINTING OFFICE
Printing Procurement Department
BID

All bids are subject to GPO Publication 310.2, Contract Terms (Rev. 6-01) which is incorporated by reference, and the representations and certifications on the reverse of part one of this GPO Form 910.

Shipment(s) will be made from: City _____, State _____

(The city(ies) indicated above will be used for evaluation of transportation charges when shipment f.o.b. contractor's city is specified. If no shipping point is indicated above, it will be deemed that the bidder has selected the city and state shown below in the address block and the bid will be evaluated and the contract awarded on that basis. If shipment is not made from evaluation point, contractor will be responsible for any additional shipping costs incurred.)

PROGRAM NO. _____ (BIDDER TO ATTACH SCHEDULE OF PRICES TO THIS BID FORM)

or

JACKET NO. _____

BID _____

Additional _____ Rate _____

Discounts are offered for prompt payment as follows: _____ percent, _____ calendar days.
See Provision 12 "Discounts" in GPO Contract Terms (Pub. 310.2).

Bidder hereby acknowledges amendment(s) number(ed) _____

In compliance with the above, the undersigned agrees, if this bid is accepted within _____ calendar days (60 calendar days unless a different period is inserted by the bidder) from the date for receipt of bids, to furnish the specified items at the price set opposite each item, delivered at the designated point(s), in exact accordance with specifications.

Notice: Failure to provide a 60 day bid acceptance period may result in expiration of your bid prior to award.

COMPANY SUBMITTING BID

PERSON AUTHORIZED TO BID

Company _____ Name _____

Address _____ Title _____

City _____ State _____ Zip _____ Signature _____

GPO Contractor Code (if known) _____ Date _____

Telephone Number _____ Facsimile Number _____

Contracting Officer Review _____ Date _____ Certifier _____ Date _____
(Initials) (Initials)

Representations and Certifications

Exception to the certifications may render your bid nonresponsive. Submission of your bid without statement of exception shall constitute certification of the six items.

REPRESENTATIONS.

R-1. Small business. By submission of a bid, the bidder represents that the bidder is a small business concern, unless the bid contains an affirmative representation that the bidder is not a small business concern.

R-2. Small Disadvantaged Business Concern. By submission of a bid, the bidder represents that the bidder is not a small disadvantaged business concern, unless the bid itself contains an affirmative representation that the bidder is a small disadvantaged business concern.

R-3. Women-Owned Small Business Concern. By submission of a bid, the bidder represents that the bidder is not a women-owned small business concern, unless the bid itself contains an affirmative representation that the bidder is a women-owned small business concern.

CERTIFICATIONS.

C-1. Covenant Against Contingent Fees. Submission of a bid without statement of exception shall constitute certification.

(a) The contractor warrants that no person or agency has been employed or retained to solicit or obtain a contract upon an agreement or understanding for a contingent fee, except a bona fide employee or agency. For breach or violation of this warranty, the Government shall have the right to annul the contract without liability or, in its discretion, to deduct from the contract price or consideration or otherwise recover, the full amount of the contingent fee.

(b) "Bona fide agency" means an established commercial or selling agency, maintained by a contractor for the purpose of securing business, that neither exerts nor proposes to exert improper influence to solicit or obtain Government contracts nor holds itself out as being able to obtain any Government contract or contracts through improper influence.

"Bona fide employee" means a person, employed by a contractor and subject to the contractor's supervision and control as to time, place, and manner of performance, who neither exerts nor proposes to exert improper influence to solicit or obtain Government contracts nor holds out as being able to obtain any Government contract or contracts through improper influence.

"Contingent fee" means any commission, percentage, brokerage, or other fee that is contingent upon the success that a person or concern has in securing a Government contract.

"Improper influence" means any influence that induces or tends to induce a Government employee or officer to give consideration or to act regarding a Government contract on any basis other than the merits of the matter.

C-2. Buy American Certification. Except as may be listed with the bid itself, the bidder certifies with the submission of a bid that each end product is a domestic end product (as defined in clause 37 "Buy American Act" in Contract Clauses), and that components of unknown origin have been considered to have been mined, produced, or manufactured outside the United States. Any exception listed with the bid itself must list both the excluded end products and the country of origin of each.

C-3. Clean Air and Water. Submission of a bid without statement of exception shall constitute certification.

(Applicable if the bid or offer exceeds \$100,000 or the Contracting Officer has determined that orders under an indefinite quantity contract in any year will exceed \$100,000, or a facility to be used has been the subject of a conviction under the Clean Air Act (42 U.S.C. 7413 (C) (1)) or the Federal Water Pollution Control Act (33 U.S.C. 1319(c)) and is listed by EPA, or is not otherwise exempt.)

(a) Any facility to be utilized in the performance of the proposed contract has not been listed on the Environmental Protection Agency List of Violating Facilities.

(b) The Contracting Officer will be promptly notified, prior to award, of the receipt of any communication from the Director, Office of Federal Activities, Environmental Protection Agency, indicating that any facility which he/she proposes to use for the performance of the contract is under consideration to be listed on the EPA List of Violating Facilities.

(c) Bidder will include substantially this certification, including this paragraph (c), in every nonexempt subcontract.

C-4. Certificate of Independent Price Determination. Submission of a bid without statement of exception shall constitute certification.

(a) The offeror certifies that-

(1) The prices in the offer have been arrived at independently, without, for the purpose of restricting competition, any consultation, communication, or agreement with any other offeror or competitor relating to (i) those prices; (ii) the intention to submit an offer; or (iii) the methods or factors used to calculate the prices offered.

(2) The prices in the offer have not been and will not be knowingly disclosed by the offeror, directly or indirectly, to any other offeror or competitor before bid opening (in the case of a sealed bid solicitation) or contract award (in the case of a negotiated solicitation) unless otherwise required by law; and

(3) No attempt has been made or will be made by the offeror to induce any other concern to submit or not to submit an offer for the purpose of restricting competition.

(b) Each signature on the offer is considered to be a certification by the signatory that the signatory-

(1) Is the person in the offeror's organization responsible for determining the prices being offered in the bid or proposal, and that the signatory has not participated and will not participate in any action contrary to subparagraphs (a) (1) through (a) (3) of this provision; or

(2)(i) Has been authorized, in writing, to act as agent for the following principals in certifying that those principals have not participated, and will not participate in any action contrary to subparagraphs (a) (1) through (a) (3) of this provision [insert full name of person(s) in the offeror's organization responsible for determining the prices offered in the bid or proposal, and the title of his or her position in the offeror's organization];

(ii) As an authorized agent, does certify that the principals named in subdivision

(b)(2)(i) of this provision have not participated, and will not participate, in any action contrary to subparagraphs (a)(1) through (a)(3) of this provision; and

(iii) As an agent, has not personally participated, and will not participate, in any action contrary to subparagraphs (a)(1) through (a)(3) of this provision.

(c) If the offeror deletes or modifies subparagraph (a)(2) of this provision, the offeror must furnish with its offer a signed statement setting forth in detail the circumstances of the disclosure.

C-5. Certification Regarding Debarment, Suspension, Proposed Debarment, and Other Responsibility Matters (Jan. 1999). By submission of a bid-

(a)(1) The offeror certifies, to the best of its knowledge and belief, that-

(i) The offeror and/or any of its principals-

(A) Are not presently debarred, suspended, proposed for debarment, or declared ineligible for the award of contracts by any Federal agency;

(B) Have not, within a 3-year period preceding this offer, been convicted of or had a civil judgment rendered against them for: commission of fraud or a criminal offense in connection with obtaining, attempting to obtain, or performing a public (Federal, state, or local) contract or subcontract; violation of Federal or state antitrust statutes relating to the submission of offers; or commission of embezzlement, theft, forgery, bribery, falsification or destruction of records, making false statements, tax evasion, or receiving stolen property; and

(C) Are not presently indicted for, or otherwise criminally or civilly charged by a governmental entity with commission of any of the offenses enumerated in subdivision (a)(1)(i)(B) of this provision.

(ii) The offeror has not, within a three-year period preceding this offer, had one or more contracts terminated for default by any Federal agency.

(2) "Principals," for the purposes of this certification, means officers; directors; owners; partners; and, persons having primary management or supervisory responsibilities within a business entity (e.g., general manager; plant manager; head of a subsidiary, division or business segment, and similar positions).

This Certification Concerns a Matter Within the Jurisdiction of an Agency of the United States and the Making of a False, Fictitious, or Fraudulent Certification May Render the Maker Subject to Prosecution Under Section 1001, Title 18, United States Code.

(b) The offeror shall provide immediate written notice to the Contracting Officer if, at any time prior to contract award, the offeror learns that its certification was erroneous when submitted or has become erroneous by reason of changed circumstances.

(c) A certification that any of the items in paragraph (a) of this provision exists will not necessarily result in withholding of an award under the solicitation. However, the certification will be considered in connection with a determination of the offeror's responsibility. Failure of the offeror to furnish a certification or provide such additional information as requested by the Contracting Officer may render the offeror non-responsible.

(d) Nothing contained in the foregoing shall be construed to require establishment of a system of records in order to render, in good faith, the certification required by paragraph (a) of this provision. The knowledge and information of an offeror is not required to exceed that which is normally possessed by a prudent person in the ordinary course of business dealings.

(e) The certification in paragraph (a) of this provision is a material representation of fact upon which reliance was placed when making award. If it later determined that the offeror knowingly rendered an erroneous certification, in addition to other remedies available to the Government, the Contracting Officer may terminate the contract resulting from the solicitation for default.

C-6. Certification of Nonsegregated Facilities (Jan. 1999). Submission of a bid without statement of exception shall constitute certification.

(a) "Segregated facilities," as used in this provision, means any waiting rooms, work areas, rest rooms and wash rooms, restaurants and other eating areas, time clocks, locker rooms and other storage or dressing areas, parking lots, drinking fountains, recreation or entertainment areas, transportation, and housing facilities provided for employees, that are segregated by explicit directive or are in fact segregated on the basis of race, color, religion, or national origin because of habit, local custom, or otherwise.

(b) By submission of an offer, the offeror certifies that it does not and will not maintain or provide for its employees any segregated facilities at any of its establishments, and that it does not and will not permit its employees to perform their services at any location under its control where segregated facilities are maintained. The offeror agrees that a breach of this certification is a violation of the Equal Opportunity clause in the contract.

(c) The offeror further agrees that (except where it has obtained identical certifications from proposed subcontractors for specific time periods) it will-

(1) Obtain identical certifications from proposed subcontractors before the award of subcontracts under which the subcontractor will be subject to the Equal Opportunity clause;

(2) Retain the certifications in the files; and

(3) Forward the following notice to the proposed subcontractors (except if the proposed subcontractors have submitted identical certifications for specific time periods);

NOTICE TO PROSPECTIVE SUBCONTRACTORS OF REQUIREMENT FOR CERTIFICATION OF NONSEGREGATED FACILITIES

A certification of Nonsegregated Facilities must be submitted before the award of a subcontract under which the subcontractor will be subject to the Equal Opportunity clause. The certification may be submitted either for each subcontract or for all subcontracts during a period (i.e., quarterly, semiannually, or annually).

Note: The penalty for making false statements in offers is prescribed in 18 U.S.C. 1001.

*****SAMPLE BID ENVELOPE*****

In order to insure proper processing of all bids, the following information is required on all contractor furnished bid envelopes:

JACKET OR PROGRAM NO. _____
FROM _____
ADDRESS _____

POSTAGE
STAMP
REQUIRED

(Please check appropriate box)

- BID
- NO BID
- CONFIRMATION OF TELEPHONE/TELEGRAPH BID

U.S. Government Printing Office
Dallas Regional Printing Procurement Office
1100 Commerce Street, Room 731
Dallas, TX 75242

BIDS WILL BE RECEIVED UNTIL

AT **3 P.M.** PREVAILING DALLAS TIME